

Rod Style Series



Rugged Rod Style Housings:

Transducers designed to survive in harsh industrial environments to reduce downtime on the plant floor.

The R10 housing, sensing rod and components are designed and constructed to withstand heavy duty applications, such as those found in lumber mills, steel mills and stamping plants. They have been lab tested and field proven to withstand 2000 g of shock and 30 g of random vibration without false signals or mechanical damage.

In addition, the **R10's** electronics are enclosed in

an aluminum housing with O-ring seals for an IP67 environmental rating.

Although R10 sensors can be ordered with any of the outputs below, the units can easily be changed in the field to reverse the output signal. Thus, one model can be used for two applications by programming the "zero" and "span" appropriately. The differential feature allows the gap distance between two magnets to be measured. The magnets must remain within the active span at all times and cannot be any closer than 2.5 inches to each other.

Rod Style Series (R10) Specifications:

	LT Analog	LTX Analog	LTX Digital	LTX SSI
Output:	4-20 mA, 20-4 mA, 0-10 VDC, 10-0 VDC	0-10 VDC, 10-0 VDC, -10 to 10 VDC, 10 to -10 VDC, 0-5 VDC, 5-0 VDC, -5 to 5 VDC, 5 to -5 VDC, 4-20 mA, 20-4 mA	RS422 Start/Stop, Variable Pulse: Internal or External interrogation	24, 25 or 26 bit, Binary or Gray Code
Span:	2-168 in	1-300 in	1-300 in	1-300 in
Repeatability:	+/-0.006% of full span or +/-0.002 in, whichever is greater	Equal to resolution	Equal to resolution of controller	Equal to output resolution
Resolution:	0.001 in / 16 bit	0.00006 in / 16 bit	Controller dependent	English: 0.00005 in, 0.0001 in, 0.0005 in, 0.001 in Metric: 1, 5, 10, 20 micron
Operating temperature:	Head (Electronics): -40 to +158 °F (-40 to +70 °C) Guide Tube: -40 to +221 °F (-40 to +105 °C)	Head (Electronics): -40 to +185 °F (-40 to +85 °C) Guide Tube: -40 to +221 °F (-40 to +105 °C)	Head (Electronics): -40 to +185 °F (-40 to +85 °C) Guide Tube: -40 to +221 °F (-40 to +105 °C)	Head (Electronics): -40 to +185 °F (-40 to +85 °C) Guide Tube: -40 to +221 °F (-40 to +105 °C)
Storage temp.	-40 to +185 °F (-40 to +85 °C)	-40 to +221 °F (-40 to +105 °C)	-40 to +221 °F (-40 to +105 °C)	-40 to +221 °F (-40 to +105 °C)
Null zone:	2.00 in	2.00 in	2.00 in	2.00 in
Dead zone:	2.50 in	2.50 in	2.50 in	2.50 in
Operating pressure:	5,000 PSI operating, 10,000 PSI spike	5,000 PSI operating, 10,000 PSI spike	5,000 PSI operating, 10,000 PSI spike	5,000 PSI operating, 10,000 PSI spike
Operating voltage:	13.5-30 VDC	7-30 VDC	7-30 VDC	7-30 VDC
Current consumption:	3 watts maximum, 200 mA at 15 VDC	1 watt at 1 ms interrogation time with no recirculations. Power consumption increases as interrogation times and recirculations increase. 40 mA at 24 VDC typical	1 watt at 1 ms interrogation time with no recirculations. Power consumption increases as interrogation times and recirculations increase. 40 mA at 24 VDC typical	1.3 watt at 1 ms interrogation time. Power consumption increases as interrogation times increase. 40 mA at 24 VDC typical
Response time:	1 ms (span length 1-50 in) 2 ms (span length 51-100 in) 3 ms (span length 101-150 in) 4 ms (span length 151-168 in)	0.5 mms (L ≤ 2") 1 ms (2" < L ≤ 12") 2 ms (12" < L ≤ 30") 3 ms (30" < L ≤ 50") 4 ms (50" < L ≤ 100") 5 ms (100" < L ≤ 150") 6 ms (150" < L ≤ 180") 7 ms (180" < L ≤ 250") 8 ms (250" < L ≤ 300")	Controller Dependent	4.0 K measurements/sec. (span length 1-12 in) 2.4 K measurements/sec. (span length 13-30 in) 2.0 K measurements/sec. (span length 31-40 in) 1.1 K measurements/sec. (span length 41-80 in) 0.5 K measurements/sec. (span length 81-197 in)
Shock:	2000 g	1000 g	1000 g	1000 g
Vibration:	30 g	30 g	30 g	30 g
Hysteresis:	+/-0.02% of full span	0.001 in	0.001 in	0.001 in
Non-linearity:	+/-0.05% of full span	< 0.01% or +/-0.005 in, whichever is greater	< 0.01% or +/-0.005 in, whichever is greater	< 0.01% or +/-0.005 in, whichever is greater
Rod end / Mounting hex:	316 stainless steel, 0.405 in (10.29 mm) outer dia.	316 stainless steel, 0.405 in (10.29 mm) outer dia.	316 stainless steel, 0.405 in (10.29 mm) outer dia.	316 stainless steel, 0.405 in (10.29 mm) outer dia.
LED:	N/A	Tri-color diagnostic	Tri-color diagnostic	Tri-color diagnostic
Protection rating:	IP67	IP68	IP68	IP68
Agency approval:	CE	CE	CE	CE

Rod Style Series

Wiring Diagrams:

LT and LTX Analog

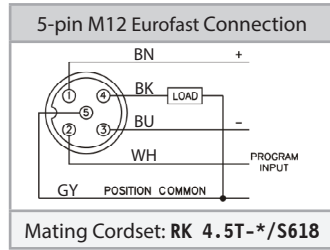

LTX Digital

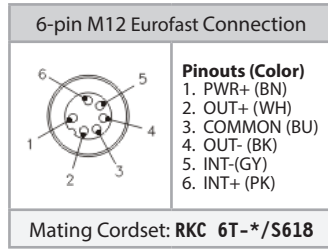

LTX SSI

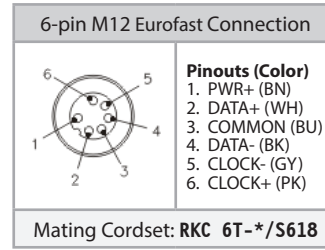

Part Number Key: Analog R10 Rod Style Series

A	B	C		D		E	F		G
LT	12	E	-	R10	-	LI	0	-	H1151

A	Type
LT	Linear Transducer

B	Measuring Span
*	Length of Measuring Span

C	Units of Measurement
E	Inches

D	Housing Size, Material
R10	10 mm Rod, Aluminum
ER10	10 mm Rod, Stainless Steel

E	Output Configuration
LI	Current
LU	Voltage
LD	Differential

F	Output Type		
	Current	Voltage	Differential
0	4-20 mA	0 to 10 V	0 to 10 V
1	20-4 mA	10 to 0 V	4-20 mA
4		0 to 5 V	
5		5 to 0 V	

G	Type of Connection
H1151	5-pin M12 Eurofast Connector

Part Number Key: LTX Analog R10 Rod Style Series

A	B	C		D		E	F	G		H
LTX	12	E	-	R10	-	LI	0	X3	-	H1151

A	Type
LTX	Linear Transducer

B	Measuring Span
*	Length of Measuring Span

C	Units of Measurement
E	Inches
M	Millimeters

D	Housing Size, Material
R10	10 mm Rod, Aluminum
ER10	10 mm Rod, Stainless Steel

E	Output Configuration
LI	Current
LU	Voltage

F	Output Type	
	Current	Voltage
0	4-20 mA	0 to 10 V
1	20-4 mA	10 to 0 V
2		-10 to 10 V
3		10 to -10 V
4		0 to 5 V
5		5 to 0 V
6		-5 to 5 V
7		5 to -5 V

G	Number of LEDs
X3	3 Diagnostic LEDs

H	Type of Connection
H1151	5-pin M12 Eurofast Connector

Rod Style Series

Part Number Key: Digital R10 Rod Style Series

A	B	C		D		E		F		G		H
LTX	12	E	-	R10	-	VPI	-	001	-	X3	-	H1161

A	Type
LTX	Linear Transducer

B	Measuring Span
*	Length of Measuring Span

C	Units of Measurement
E	Inches
M	Millimeters

D	Housing Size, Material
R10	10 mm Rod, Aluminum
ER10	10 mm Rod, Stainless Steel

E	Output Mode
RS	RS422, Start/Stop Pulse
VPE	Variable Pulse External Interrogations
VPI	Variable Pulse Internal Interrogations

F	Number of Recirculations ¹⁾
*	001 (Standard) to 225

¹⁾ Only Available with Output Mode 'VPI' or 'VPE'. Otherwise (Blank)

G	Number of LEDs
X3	3 Diagnostic LEDs

H	Type of Connection
H1161	6-pin M12 Eurofast Connector

Part Number Key: SSI R10 Rod Style Series

A	B	C		D		E		F		G	H	I	J		K		L		M
LTX	12	E	-	R10	-	SSI	-	1	-	B	S	F	B	-	X3	-	A	-	H1161

A	Type
LTX	Linear Transducer

B	Measuring Span
*	Length of Measuring Span

C	Units of Measurement
E	Inches
M	Millimeters

D	Housing Size, Material
R10	10 mm Rod, Aluminum
ER10	10 mm Rod, Stainless Steel

E	Data Mode
SSI	Synchronous Serial Interface

F	Data Length
1	24 bit
2	25 bit
3	26 bit

G	Data Format
B	Binary Code
G	Gray Code

H	Data Type
A	Asynchronous
S	Synchronous

I	Direction
F	Forward
R	Reverse
V	Velocity

J	Resolution
1	0.005 mm
2	0.01 mm
3	0.05 mm
4	0.1 mm
5	0.02 mm
6	0.002 mm
7	0.001 mm
8	0.00005"
9	0.0001"
A	0.0005"
B	0.001"

K	Number of LEDs
X3	3 Diagnostic LEDs

L	Option
(Blank)	None
A	Alarm

M	Type of Connection
H1161	6-pin M12 Eurofast Connector

Rod Style Series Accessories

1" Diameter Cylinder Magnet

CM-R10

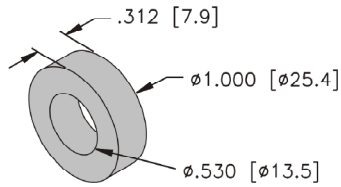

Standard Magnet Spacer

STS-R10

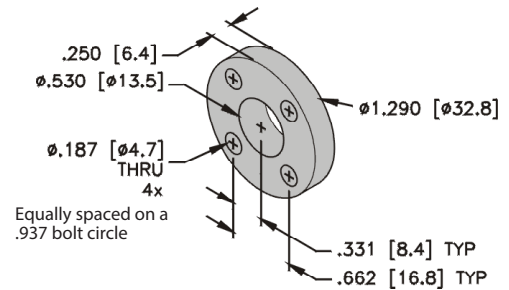

Split Magnet Spacer

SPS-R10

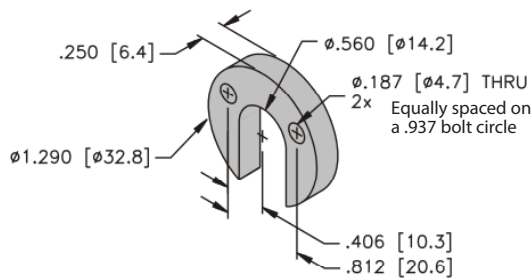

Egg Shape Float

EF-R10

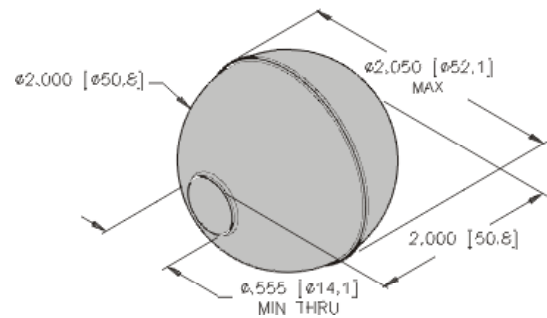

Standard 4-Hole Magnet

STM-AL-R10 (aluminum)
STM-SS-R10 (stainless steel)

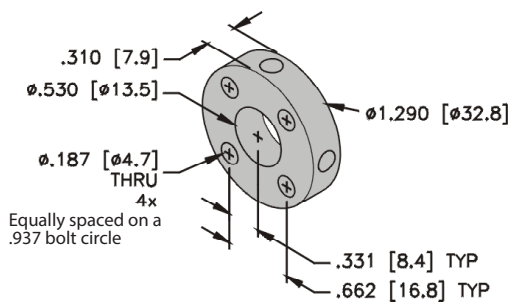

Split Magnet

SPM-AL-R10

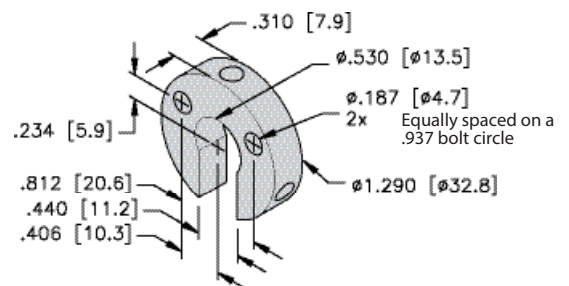

All dimensions shown as: inches [mm]

Linear Position Technology

Rod Style Series Accessories

Mounting Bracket
LB-R10

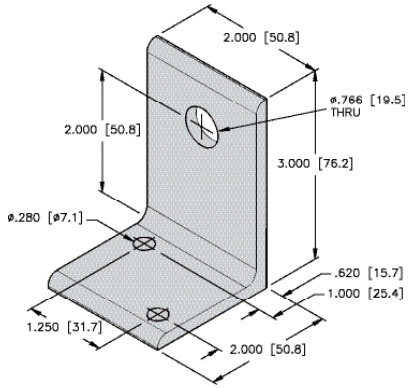

Rod Support
RB-R10

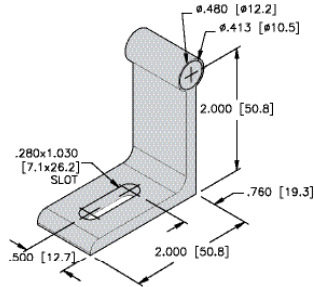

Magnet Mounting Bracket
MMB-R10

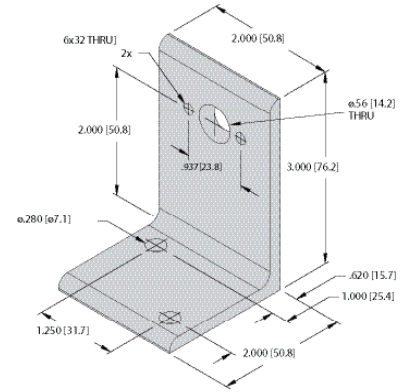

MB-R10: Part number includes mounting bracket **LB-R10** and rod support bracket **RB-R10**.

Test and Programming Device
TB2-LDT
TB2-LDT-LI

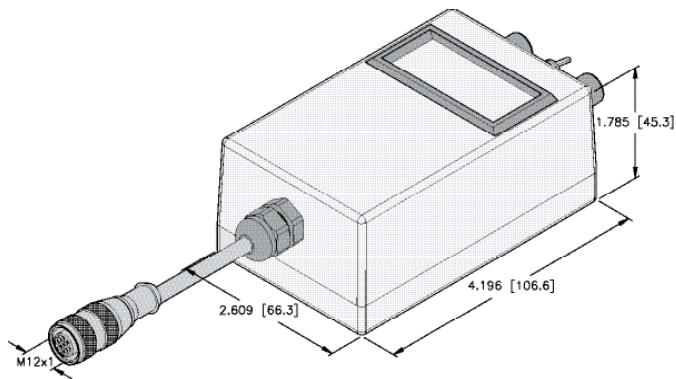

Rubber Boot
BT-R10

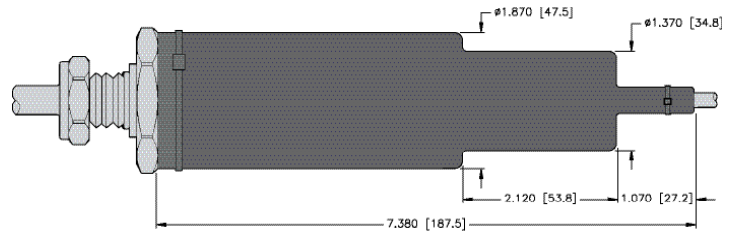

All dimensions shown as: inches [mm]